



# SHIMANO

## **SHIMANO AMERICAN CORPORATION**

One Holland, Irvine, California 92618, U.S.A. Phone: +1-949-951-5003

## **SHIMANO EUROPE HOLDING B.V.**

Industrieweg 24, 8071 CT Nunspeet, The Netherlands Phone: +31-341-272222

## **SHIMANO INC.**

3-77 Oimatsu-cho, Sakai, Osaka 590-8577, Japan

These service  
instructions are printed  
on recycled paper.

Please note: specifications are subject to change for improvement without notice.

©Feb. 2004 by Shimano Inc. XBC IZM Printed in Japan

SI-7AP1D

SERVICE INSTRUCTIONS  
MONTAGE-INSTRUCTIES  
EINBAUANLEITUNG  
INSTRUCTIONS DE MONTAGE  
INSTRUCCIONES DE SERVICIO  
取扱説明書  
ISTRUZIONI per l'ASSISTENZA  
MANUAL DE INSTRUÇÕES  
SERVICEVEJLEDNING  
BRUKSANVISNING  
ΟΔΗΓΙΕΣ ΣΕΡΒΙΣ  
HUOLTO-OHJEET  
使用说明书

**Cycle Computer**

**FLIGHT DECK**

**SC-6502/SC-6501/SC-M500**

**SHIMANO**

<b>English</b>	<b>3 – 24</b>
<b>Dutch</b>	<b>25 – 46</b>
<b>German</b>	<b>47 – 68</b>
<b>French</b>	<b>69 – 90</b>
<b>Spanish</b>	<b>91 – 112</b>
<b>Japanese</b>	<b>113 – 134</b>
<b>Italian</b>	<b>135 – 156</b>
<b>Portuguese</b>	<b>157 – 178</b>
<b>Danish</b>	<b>179 – 200</b>
<b>Swedish</b>	<b>201 – 222</b>
<b>Greek</b>	<b>223 – 244</b>
<b>Finnish</b>	<b>245 – 266</b>
<b>Chinese</b>	<b>267 – 288</b>

# Cycle Computer

## SC-6502/SC-6501/SC-M500

### INDEX

<b>1. Display Modes</b> .....	<b>5</b>
<b>2. Display Contents</b> .....	<b>6</b>
<b>3. Name and function of each part</b> .....	<b>8</b>
• Current speed (VEL) .....	<b>9</b>
• Gear indicator (bar) • Time display (CLK)	
• Trip distance group (TIM, DST, MAX, AVE) .....	<b>10</b>
• Pace Arrow	
• ODO meter (ODO) .....	<b>11</b>
• Stopwatch (STW) group	
• Cadence (rpm) .....	<b>12</b>
• Main display cadence (VEL) • Lap counter (CNT)	
• Digital number of gear teeth (F-R) .....	<b>13</b>
• Low battery display (LO BAT)	
• Power saver function	
<b>4. Changing the setting data</b> .....	<b>14</b>
<b>and the bicycle number</b>	
<b>5. Viewing data after removing the</b> .....	<b>15</b>
<b>computer from the bracket mount</b>	
<b>6. Setting tolerances</b> .....	<b>15</b>
<b>7. Installation to the bicycle</b> .....	<b>16</b>
<b>8. Data input</b> .....	<b>17</b>
<b>Replacing the battery</b> .....	<b>23</b>
<b>Using the sticker</b> .....	<b>24</b>
<b>Trouble Shooting</b> .....	<b>24</b>

**WARNING**

**Be careful not to pay excessive attention to the computer data while riding, otherwise you might have an accident.**

## Specifications

Meter	SC-6502	SC-6501 / SC-M500		
Bracket/Sensor unit	SM-SC70	SM-6501	SM-6501-MD	SM-6501-M
STI lever	ST-7800	ST-7700-C ST-6510 ST-5500-CA ST-4400 ST-3300/3303	ST-M510 SL-M510	ST-M952 SL-M952 ST-M750 SL-M750 ST-M570 SL-M570

## NOTE;

- \* The all clear (AC) button is used to clear the main unit memory.
- \* Never disassemble the main unit, as it cannot be reassembled.
- \* The main unit is fully waterproofed to withstand wet weather conditions; however, do not deliberately place it into water.
- \* Avoid leaving the main unit exposed to extremely hot weather conditions.
- \* Handle the main unit carefully, and avoid subjecting it to any shocks.
- \* Do not use thinner or other solvents to clean parts such as the main unit and sensor, as they may dissolve the part casings.
- \* To clean these parts, wipe them with a cloth soaked in a weak mixture of neutral detergent and water.
- \* If using the SM-6501/M/MD together with an LED lamp from another manufacturer, the speed measurement function may not work correctly.  
If using an LED lamp from another manufacturer, it is recommended that you use the SM-6500-RS.

# 1. Display Modes

“Current speed” and “Gear indicator (bar)” are always displayed

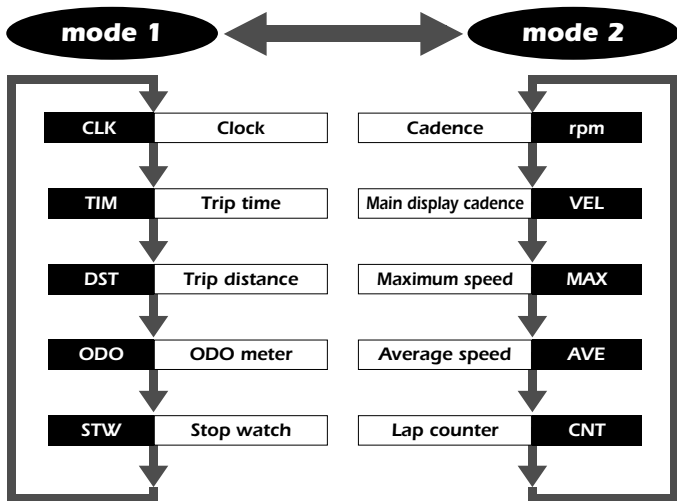

SM-SC70  
SM-6501

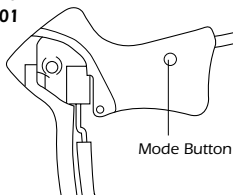

SM-6501-MD

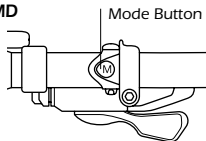

SM-6501-M

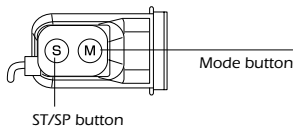

↓  
Press mode button  
once



Press mode button continuously  
for 2 seconds or more

# 2. Display Contents

## mode 1

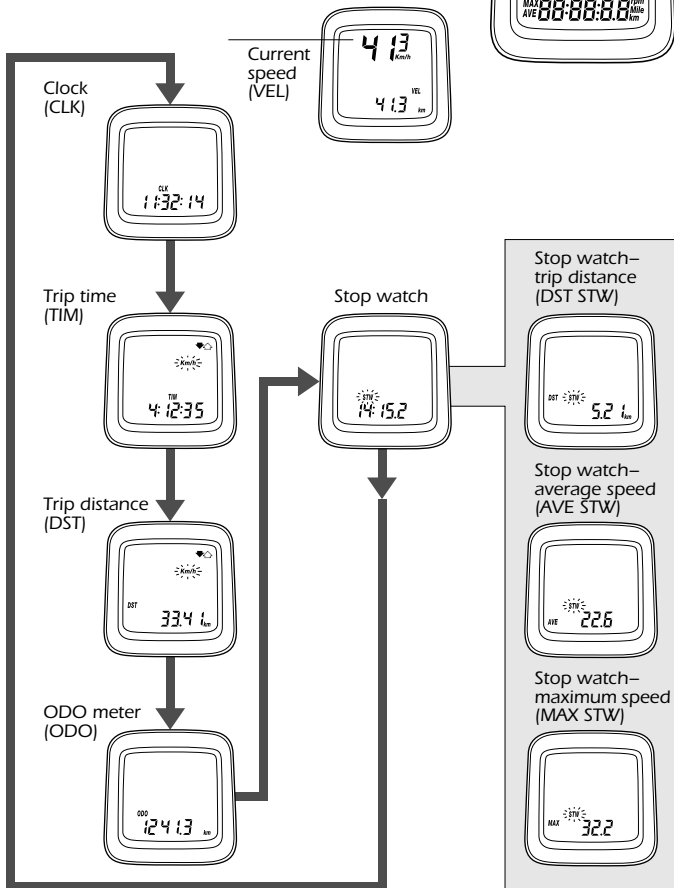

## mode 2



Cadence  
(rpm)



Main display  
cadence



Lap counter

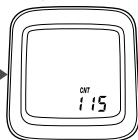

No. of gear teeth  
(digital)

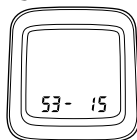

Maximum  
speed



Gear indicator  
(bar)

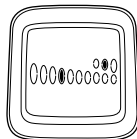

Average  
speed

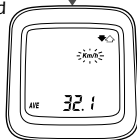

Pace Arrow



Low battery display

**LO BAT**

# 3. Name and function of each part

## Front



## Rear

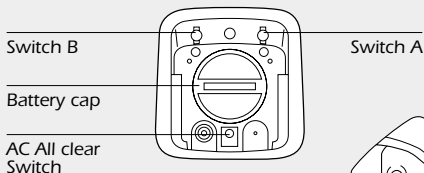

## STI Brake Bracket

<ST-7800, ST-7700-C, ST-6510,  
ST-5500-CA, ST-4400, ST-3300/3303>

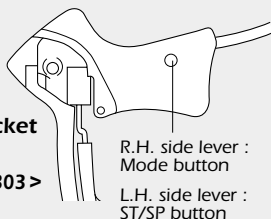

<ST-M510, SL-M510>

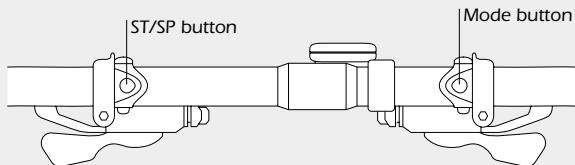

<ST-M952, ST-M750, ST-M570,  
SL-M952, SL-M750, SL-M570>

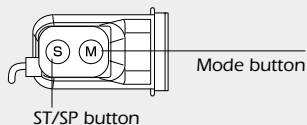

## (1) Current speed (VEL)

km/h, mph



When main display cadence appears on top

Current speed will appear in the sub - display

0.0 (2.0) - 130.0km/h  
0.0 (1.2) - 80.0mph (Range)  
The current speed will appear at the top of the main display.

## (2) Gear indicator (bar)

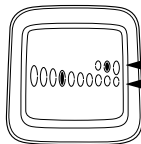

Front display

For double : Low position . . . . ○○○○●○○○○○

For triple : Middle position . . . ○○○○●○○○○○

For single : . . . . . ○○○○○○●○○○○○

Rear display

Gear indicator bar will not appear if the sensor wire is not connected or it has been turned off.

**Displays;** Top for smallest sprocket  
Low for largest sprocket

7th sprocket for 10-sprocket set . . . . ○○○○●○○○○○

7th sprocket for 9-sprocket set . . . . ○○○○●○○○○○

7th sprocket for 8-sprocket set . . . . ○○○○●○○○○○

7th sprocket for 7-sprocket set . . . . ○○○○●○○○○○

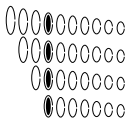

## (3) Time display (CLK)

24-hours clock



Clock will appear when changing mode 2 to mode 1 and during power saver function.

## (4) Trip distance group (TIM, DST, MAX, AVE)

The trip distance group includes the trip time (TIM), trip distance (DST), maximum speed during the trip (MAX) and the average speed during the trip (AVE). To activate the trip distance group, press the Mode button until "TIM" is displayed, and then press the ST/SP button.

### Trip time (TIM)

0-99:59:59 [h;min;sec]

### km/mile flashes



ST/SP button



ST/SP button



### Trip distance (DST)

0-999.99 (km, mile)

TIM group (automatic stop and start) start is activated

TIM group is deactivated



### Maximum speed (MAX)

0.0 (2.0) - 130.0km/h



### Average speed (AVE)

0.0 (2.0) - 130.0km/h

0.0 (1.2) - 80mph.



< Reset to zero >

Press the ST/SP button and the Mode button simultaneously while this group is active.

## Pace Arrow

Moves when distance time is operating.

The upward arrow indicates that the current speed is faster and the downward arrow indicates that the current speed is slower than the average speed for the trip.



### Note;

- To calculate the average speed, You must travel for more than 10 seconds or more.
- If the trip time exceeds 100hours or the trip distance exceeds 1,000kilometers (620miles), "ER" will be displayed and the pace arrow comparison will disappear. However, TIM and DST measurements will start again from zero and the MAX speed will be retained.

## (5) ODO meter (ODO)

0-99999.9 km, mile



Displays the cumulative distance travelled.

## (6) Stopwatch (STW) group

This group includes stopwatch trip distance average speed and maximum speed. The stopwatch is activated by pressing ST/SP button. While the stopwatch group is operating the stopwatch (STW) display will flash. Stopwatch trip distance (DST,STW) records total during STW function. Stopwatch average speed (AVE,STW) records the average speed during STW function. Maximum speed (MAX,STW) records the Maximum speed during the stopwatch function.

### < Starting and stopping >

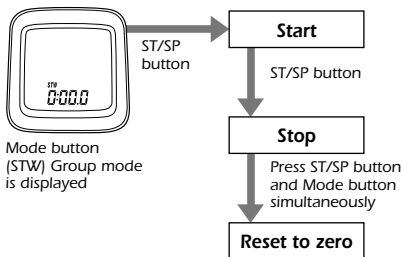

### Note:

The functions of this group are only available when stopwatch is activated. If the trip distance mode is also activated simultaneously, it is not possible to view at the distance. However the trip distance, average speed and maximum speed will still be recorded during this time.

### Stopwatch (STW)

0.0-90:00 (min,sec)



### Stopwatch trip distance (DST,STW)

km mile

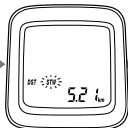

### Stopwatch average speed (AVE,STW)

km/h mile/h



### Stopwatch maximum speed (MAX, STW)

km/h mile/h



switch "B"

## (7) Cadence (rpm)



Cadence is calculated from the F-R gear tooth numbers and current speed.

### **Note;**

Cadence always appears during bicycle movement regardless if the crankarms are rotating.

## (8) Main display cadence (VEL)



Cadence (rpm) can also be shown in main display. Current speed will move to sub-display.

Cadence on main display

Current speed on sub-display

## (9) Lap counter (CNT)

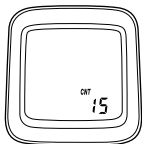

This function is used to count laps, etc. (range 0 - 99)

Lap counter is activated by pressing the ST/SP button.

To reset the counter to zero, press mode and ST/SP button simultaneously.

## (10) Digital number of gear teeth (F-R)

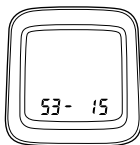

Gear combinations are displayed when a shift has been made. This will show for approx 2 seconds then original screen will return.

## (11) Low battery display (LO BAT)

This flashes when the remaining battery power is low. The battery should be replaced with a new one as soon as possible.

**LO BAT**

## (12) Power saver function

When the computer does not receive a signal or no button is pressed during a 30-minute period, the unit will change to power saver function, and only the clock will appear on the display.

### Canceling power save mode

The normal display will return as soon as switch "A" or switch "B" is pressed.

### Note:

During the stopwatch function the stopwatch will continue to operate even when the power saver function has been activated. The stopwatch will stop automatically after 90minutes have passed.

Switch "A" or switch "B"



Bicycle number display

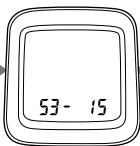

No. of gear teeth display



Display mode

## 4. Changing the setting data and the bicycle number

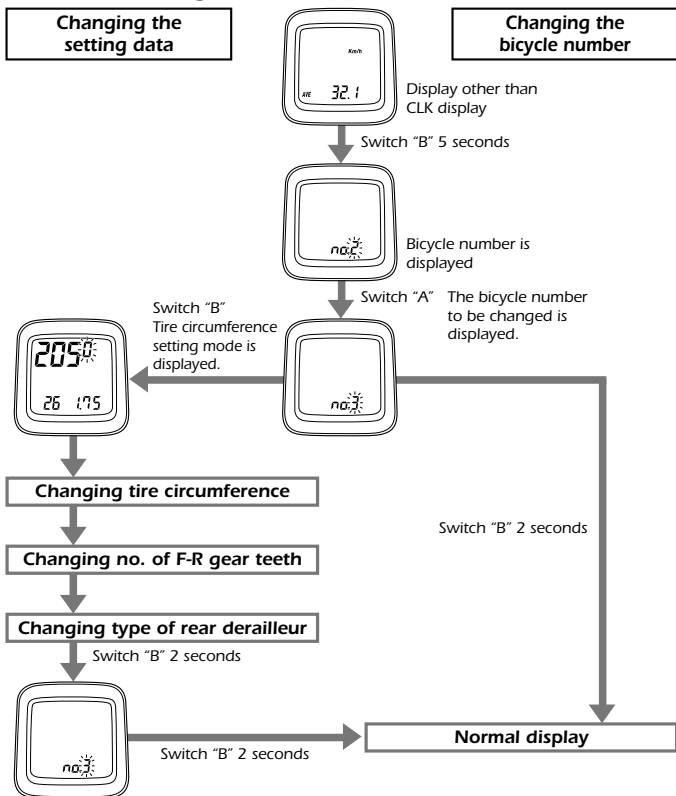

- Refer to "8. Data input".
- To change the time setting, change the sub-display to show the CLK display, and then press switch "B" for 5 seconds or more and then enter the new time setting.
- This function lets you reset input data without losing any data that has been recorded up to that point (such as total distance and trip distance).

## 5. Viewing data after removing the computer from the bracket mount

The data can still be viewed even when the computer has been removed from the handlebar bracket.

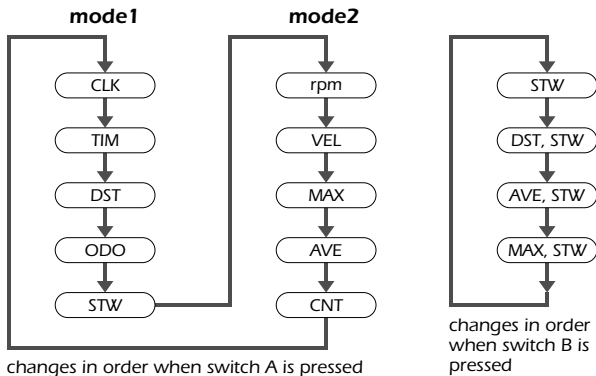

## 6. Setting tolerances

VEL .....	±1%
DST, ODO .....	0.05%
CLK .....	30ppm (5minutes or less per month)
STW, TIM .....	50ppm

# 7. Installation to the bicycle

Install the levers to the handlebars. Then connect and adjust the brake and shifting cables. Refer to the STI Lever Service Instructions for details on these procedures.

## (1) Installing the signal cable (SM-SC70/SM-6501)

Install the signal cable as shown in Figure No1.

Fig.1

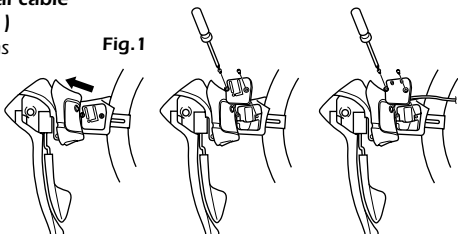

Tightening torque:  
0.3 - 0.5 N·m  
{ 2 - 4 in. lbs. }

\* For the SM-6501-M, SM-6501-MD refer to the Service Instructions included.

## (2) Installing the computer

Install the band and the bracket as shown in Figure No2.

( SM-SC70/SM-6501 )

( Tape the signal cable to the handlebars. )

## (3) Slide the computer onto the bracket until it clicks into its place.

as shown in Figure No3.

Fig.3

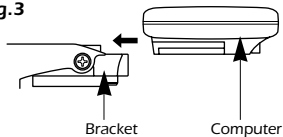
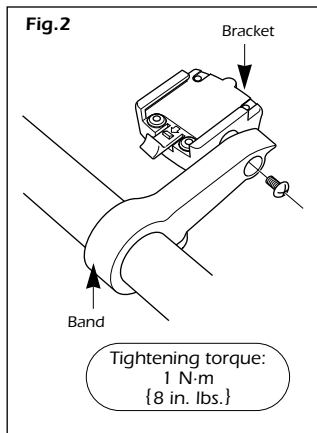

Fig.2



Tightening torque:  
1 N·m  
{ 8 in. lbs. }

( SM-SC70/SM-6501 )

( After this, wrap handlebar with finishing tape around the handlebars to secure both the signal cable and the brake cable. )

#### (4) Installing the magnet and sensors

Use a screwdriver to temporarily secure the magnet to a spoke on the right hand side of the front wheel as shown in fig4.

Put a rubber shim between the fork and the sensor as shown in fig5.

(Fork diameter range is 11 -35mm)

Place the magnet on the sensor line as shown in the illustration.

Adjust the position of the magnet so that the distance between the magnet and the sensors is 1-5 mm. Secure the magnet and the sensors firmly in these positions.

Set the positions so that the distance between the meter and the sensor are within the following:

Vertical: 50 cm

Horizontal: 10 cm

Fig.4

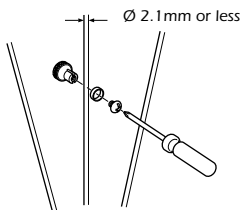
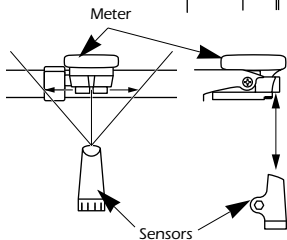
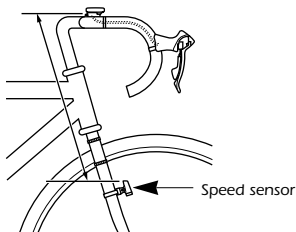
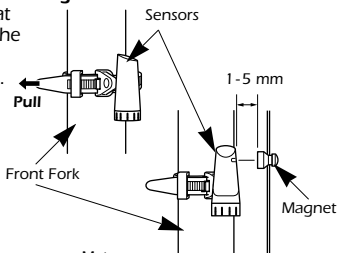

Fig.5



## 8. Data input (\*data for up to 4 bicycles can be entered)

- |                        |   |
|------------------------|---|
| 1. Km or Miles         | 4. No. of chainring and sprocket teeth* |
| 2. ODOmeter data       | 5. Type of rear derailleur*             |
| 3. Tire circumference* | 6. Current time                         |

First measure the tire circumference and check the number of chainring and sprocket teeth.

To measure the tire circumference, first ensure that the tire is inflated to the standard tire pressure. Make a mark on the tire and the ground at the point where the tire touches the ground, and move the bicycle forward one full revolution of the front wheel while seated on the bicycle, Mark the point where the marking on the tire touches the ground again. Measure the distance between the two points in millimeters. Round the distance to the nearest multiple of 5mm.

<b>Example</b>
2028 - 2032mm . . . . . 2030mm
2033 - 2037mm . . . . . 2035mm
2038 - 2042mm . . . . . 2040mm

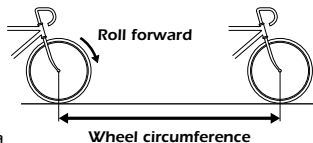

Check whether the front chainwheel is a single, double or triple chainwheel.

**Example**

53 . . . . . Single

53x39 . . . . . Double

48x38x28 . . . . . Triple



Check whether the cassette has 7, 8, 9, or 10 sprockets.

<b>Example</b>
12, 13, 14, 15, 16, 17, 18, 19, 21, 23 . . . 10 sprocket
12, 13, 14, 15, 16, 17, 19, 21, 23 . . . . . 9 sprocket

**(1) Selecting Km or Miles**

When switch "AC" (All Clear) is pressed, the display as shown in fig6 appears and the k/h setting starts flashing. Select your choice for Km/h or Mile/h by pressing switch "A". Once your choice is displayed, press switch "B" continuously for 2 seconds or more to set.

**Fig.6**

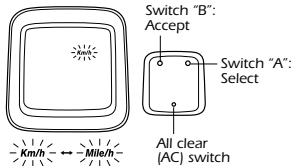

**(2) Entering odometer data**

The display will change as shown in Fig. 7. For each column, press switch "A" so that a numeral is displayed, and then press switch "B" to accept the setting. After entering the single decimal place numeral, press switch "B" for 2 seconds or more. If not entering odometer data, press switch "B" for 2 seconds or more when the display appears as shown in Fig. 7.

**Fig.7**

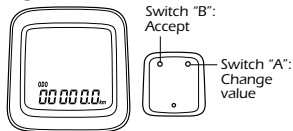

**(3) Entering the tire circumference**

The display will change as shown in Fig. 8. Press switch "A" to display the bicycle number that you would like to change, and press switch "B" for 2 seconds or more. Because of the preset chainring and sprocket tooth configurations used, bicycle numbers 1 and 2 are recommended for road bicycles and bicycle numbers 3 and 4 are recommended for MTB bicycles.

**Fig.8**

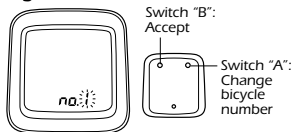

The display will appear as shown in fig9. Enter the value which was measured previously.

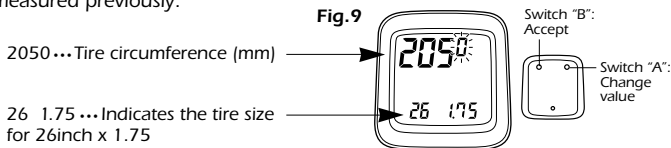

The value will increase by 5mm each time switch "A" is pressed.

The value will change rapidly when switch "A" is pressed continuously.

Once the desired value is displayed, press switch "B" for 2 seconds or more to set.

In the case of tires which have circumference of less than 2050mm, press switch "A" continuously. After the value increases to 2400, it will change to 1300.

Continue pressing switch "A" until the desired value is reached, and then press switch "B" 2 seconds or more to set.

The tire size display can appear as any one of the following 18 displays, in addition to 26 x 1.75 (2050mm)

### Tires with sizes other that these are not displayed

ETRTO	Main Display	Sub Display	ETRTO	Main Display	Sub Display
23-571	1970	26 1.00	57-559	2095	26 2.20
32-584	2005	26 1.40	40-584	2100	26 1-1/2
40-559	2030	26 1.50	54-571	2100	26 2.35
47-559	2050	26 1.75	20-622	2100	700 20
18-622	2070	700 18	23-622	2105	700 23
50-559	2070	26 1.90	25-622	2115	700 25
37-590	2075	26 1-3/8	28-622	2135	700 28
47-559	2075	26 1.95	57-559	2260	26 2-1/8
54-559	2085	26 2.00			
19-622	2090	700 19			
54-559	2090	26 2.10			

\* If the tire circumference matches one of those in this list, the tire size is displayed alternately.

#### (4) Entering the number of chainring and sprocket teeth

The display will then change to that shown in fig10.

**Fig.10**

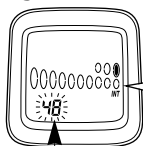

No. of teeth for largest chainring

Switch "B":  
Accept

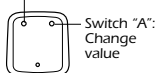

Switch "A":  
Change  
value

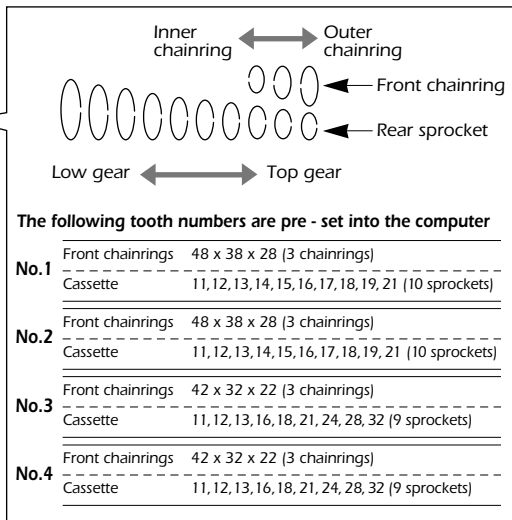

Enter the values starting from the outer chainring. "48" (or "42" if no. 3 or 4 has been selected) will flash on the display. Press switch "A" until the desired setting is displayed, and then press switch "B" to accept the new setting. (Setting range: 60-40)

The "--" is displayed once for every five times the value is changed.

If this value is set for the outer chainring by switch "B", all gear indicator related screen display will be eliminated.

When switch "A" is pressed for 2 seconds or more, the value will change rapidly.

After the value for the largest chainring has been set, the display will change to that shown in Fig. 1.

For single chainwheel, press switch "A" until "--" is displayed and then press switch "B".

**Fig.11**

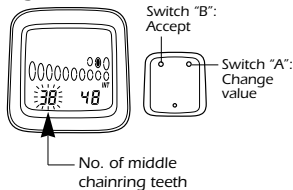

Enter the number of teeth for the inner chainring (for double front chainwheel) or the middle chainring (for triple front chainwheel).

"38" (or "32" if no. 3 or 4 has been selected) will flash on the display. This position can be set from 20 - 50 by the same procedure of setting outer chainring. After setting the inner chainring or the middle chainring, the display will change to that shown in fig12.

Fig.12

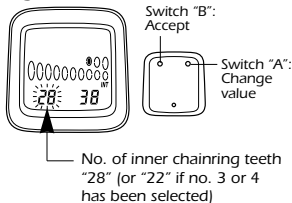

When using a double front chainwheel, press switch "A" once so that "--" is displayed, and then press switch "B" once to set, the front chainwheel will then be registered as a double front chainwheel and the display will change to show the rear sprocket settings. **(Note: Switch "B" should be pressed and released immediately. If you press it for more than 2 seconds, the next rear derailleur type will be displayed for data entry.)** When using a triple front chainwheel, the value can be set from 15 to 34 by the same procedure of setting middle chainring.

Enter the number of sprocket teeth.

The display will then change to that shown in fig13.

Fig.13

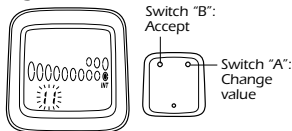

Enter the number of teeth for each sprocket by the same procedure as that used for the chainrings.

Press switch "A" to set the desired number of teeth, and then press switch "B" to accept the setting. The value can be set from 11 to 42. Once the setting for smallest sprocket through to the 7th sprocket have been made, the display will change to that shown in fig14.

Fig.14

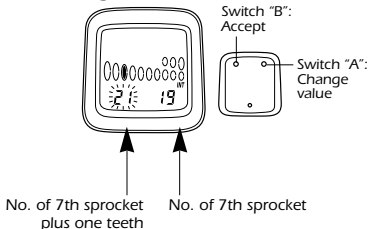

If the cassette has seven sprockets, press switch "A" once to change the flashing "21" to "--", and then press switch B once. This will indicate that there is no 8th sprocket, and the operation for entering the number of sprocket teeth will be complete.

If the cassette has 8 sprockets, enter the number of teeth for this position and follow the same procedure as above to enter "--" in the 9th position otherwise enter the number of teeth for the 9th sprocket. If the cassette has 10 sprockets, enter the number of teeth for the 10th sprocket.

### Checking the number of teeth entered

Once the setting of number of sprocket teeth is completed, the display will return to the initial input display. Re check all values by repeatedly pressing switch "B" to confirm each number of teeth. Press switch "B" once each time and check whether the entered number of teeth are matching with the sprocket position on the display.

If all values entered are correct, press switch "B" for 2 seconds or more to continue the next entry procedure.

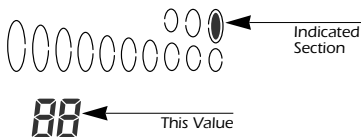

### (5) Entering the type of rear derailleur

The display will change to that shown in fig 15. The display will change from "111" to "222" each time switch "A" is pressed.

111 . . . . .	for Traditional rear derailleur
222 . . . . .	for Rapid Rise Rear derailleur (reverse spring type)

Fig.15

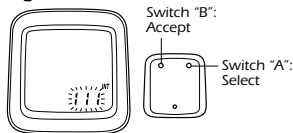

Press switch "B" for 2 seconds or more to continue the next entry procedure.

### (6) Setting the time (24 hour format)

The display will change to that shown in fig 16.

Set the time to one minute later than the current time.

Fig.16

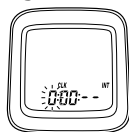

**Example**  
 If the time is 10:46:23 . . . . 10:47:--  
 If the time is 13:59:16 . . . . 14:00:--

The hours will advance when switch "A" is pressed. If switch "A" is pressed continuously, the hours will advance rapidly. Press switch "B" once to set the hour.

The minutes section will then start flashing as shown in Fig 17.

Set the minutes in the same procedure as for setting the hours. The clock will then start.

Fig.17



To continue entering data for a different bicycle number, change the sub-display to a display other than the CLK display, and then press switch "B" for 5 seconds or more. The press switch "A" until the bicycle number to be entered is displayed and then press switch "B" again. Refer to "4. Changing the setting data" for details on entering new data.

## Note; To reset clock

Get a display where CLK appears on the sub - display. Press switch "B" for 5 seconds or more to change the time setting.

## Replacing the battery

### ▪ Meter (CR-2032 battery)

Insert the battery so that the (+) side is visible as shown in Fig. 18, and then tighten the battery cap.

The battery which is installed at the time of purchase is for monitoring purposes. If the **LO BAT** low battery indicator appears, replace the battery as soon as possible.

### ▪ Sensor (LR44 battery)

Insert the battery so that the (+) side is visible as shown in Fig. 19, and then tighten the battery cap.

Fig.18

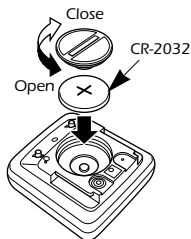
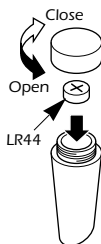

Fig.19



## Note;

If the speed does not display correctly even though the LO BAT low battery indicator does not appear, replace the sensor battery.

## Using the sticker

If the gear indicator (bar) does not display correctly, attach the accessory sticker in the position shown in the illustration.

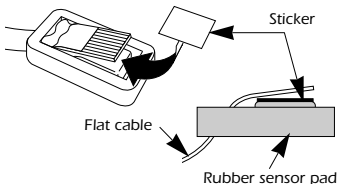

## Trouble Shooting

### \* Speed is not displayed.

- Check that the speed sensor and the main unit are positioned correctly (distance and facing direction).
- Check that the positions of the speed sensor and magnet are correct.
- Check that the main unit is fixed correctly to the bracket.

### \* Display does not appear or is faint.

- Poor main unit contact, or battery is depleted. Replace the main unit battery with a new one.

### \* Incorrect data is displayed.

- Press the A/C button to re-enter the data.

### \* Display is dark.

- This is because the main unit has become hot and has been affected by long-term exposure to direct sunlight, such as can occur during hot weather. Store the main unit in a cool, shady place so that it can cool down and return to normal.

### \* Data display movement is slow.

- The computer operating temperature range is  $-10^{\circ}\text{C}$  to  $50^{\circ}\text{C}$ . Check that the temperature is not lower than  $-10^{\circ}\text{C}$ .