

## General Safety Information

### WARNING

- Be careful not to let the cuffs of your clothes get caught in the chain while riding, otherwise you may fall off the bicycle.
- Check that the tension of the chain is correct and that the chain is not damaged. If the tension is too weak or the chain is damaged, the chain should be replaced. If this is not done, the chain may break and you may fall off the bicycle.
- The two left crank arm mounting bolts should be tightened alternately in stages rather than each bolt being fully tightened all at once. Use a torque wrench to check that the final tightening torques are within the range of 12 - 15 N·m. Furthermore, after riding approximately 100 km (60 miles), use a torque wrench to re-check the tightening torques.
- It is also important to periodically check the tightening torques.
- If the tightening torques are too weak or if the mounting bolts are not tightened alternately in stages, the left crank arm may come off and the bicycle may fall over.
- Check that there are no cracks in the crank arms before riding the bicycle. If there are any cracks, the crank arm may break and you may fall off the bicycle.
- Obtain and read the service instructions carefully prior to installing the parts. Loose, worn, or damaged parts may cause injury to the rider.
- We strongly recommend only using genuine Shimano replacement parts.
- Read these Technical Service Instructions carefully, and keep them in a safe place for later reference.

### Note

- Before riding the bicycle, check that there is no play or looseness in the connection. Also, be sure to retighten the crank arm fixing bolt at periodic intervals. (BB-FC, FC-PD)
- If you feel any looseness in the bottom bracket axle, the bottom bracket should be replaced.
- In addition, if pedaling performance does not feel normal, check this once more.
- Do not wash the bottom bracket with high-pressure jets of water.
- Apply grease to the bottom bracket before installing it.
- If the chain keeps coming off the chainring during use, replace the chainrings and the chain.
- You should periodically wash the chainring in a neutral detergent and then lubricate them again. In addition, cleaning the chain with neutral detergent and lubricating it can be an effective way of extending the useful life of the chainring and the chain.
- Parts are not guaranteed against natural wear or deterioration resulting from normal use.
- For maximum performance we highly recommend Shimano lubricants and maintenance products.
- For any questions regarding methods of installation, adjustment, maintenance or operation, please contact a professional bicycle dealer.

## Technical Service Instructions

SI-1HE0B

# FC-MX70

Front chainwheel

# SHIMANO

SHIMANO AMERICAN CORPORATION  
One Holland, Irvine, California 92618, U.S.A. Phone: +1-949-951-5003

SHIMANO EUROPE B.V.  
Industrieweg 24, 8071 CT Nunspeet, The Netherlands Phone: +31-341-272222

SHIMANO INC.  
3-77 Oimatsu-cho Sakai-ku, Sakai, Osaka 590-8577, Japan

These service instructions are printed on recycled paper.  
Please note: specifications are subject to change for improvement without notice. (English)  
© Sep. 2006 by Shimano Inc. XBC SZK Printed in Japan.

## Specifications

Model number	FC-MX70 (SM-CR80)
Chainwheel tooth combination	34 / 38 / 41 / 42 / 43 / 44 / 46 T
Bolt circle diameter	104 mm
Crank arm length	165, 170, 175, 180 mm
Pedal threads	B.C. 9/16" x 20T.P.I. (English thread)
Applicable chain	CN-7701
Chain line	44 mm
Shell width (Thread dimensions)	68 mm (1.37 X 24 T.P.I.)

## Installation of the chainring (SM-CR80)

Install the chainring to the right-side crank arm as shown in the illustration.

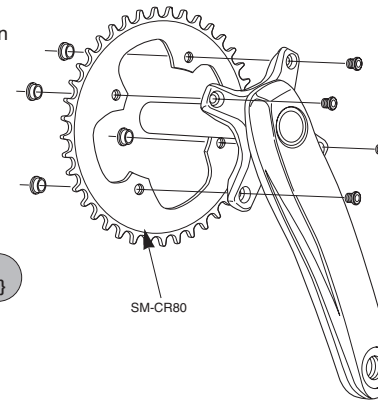

Tightening torque :  
14 - 16 N·m {122 - 139 in. lbs.}

SM-CR80

## Installation of the front chainwheel

Follow the procedure in the figure.

- 1, 2 Use the special tool TL-FC32 to install the right adapter (counterclockwise thread) and the left adapter (clockwise thread).  
Tightening torque: 35 - 50 N·m {305 - 435 in. lbs.}
- 3 Insert the right crank unit.
- 4 Set section A of the left crank into the axle of the right crank unit where the groove is wide.
- 5 Use the TL-FC16 to tighten the cap.  
Tightening torque: 0.7 - 1.5 N·m {6 - 13 in. lbs.}
- 6 Push in the stopper plate and check that the plate pin is securely in place, and then tighten the bolt of the left crank arm.

**Note :** Each of the bolts should be evenly and equally tightened to 12 - 15 N·m {106 - 132 in. lbs.}.

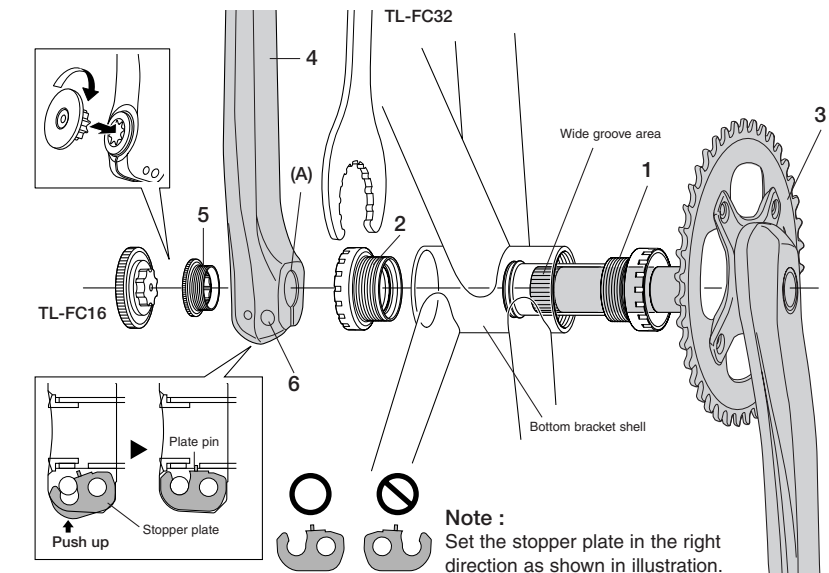

## Spacer installation method

- (1) Check whether the width of the bottom bracket shell is 68 mm.
- (2) Next, install the adapter while referring to the illustrations below.

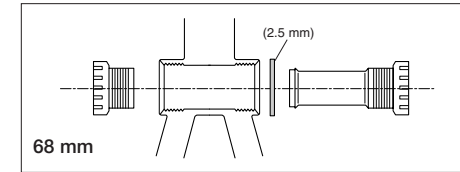
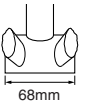

When installing the pedals, be sure to place pedal spacers on both the left and right crank arms.

