

## General Safety Information

### WARNING

- Be careful not to let the cuffs of your clothes get caught in the chain while riding, otherwise you may fall off the bicycle.
- Check that the tension of the chain is correct and that the chain is not damaged. If the tension is too weak or the chain is damaged, the chain should be replaced. If this is not done, the chain may break and you may fall off the bicycle.
- The two left crank arm mounting bolts should be tightened alternately in stages rather than each bolt being fully tightened all at once. Use a torque wrench to check that the final tightening torques are within the range of 12 - 14 N·m. Furthermore, after riding approximately 100 km (60 miles), use a torque wrench to re-check the tightening torques. It is also important to periodically check the tightening torques. If the tightening torques are too weak or if the mounting bolts are not tightened alternately in stages, the left crank arm may come off and the bicycle may fall over, and serious injury may occur as a result.
- Check that there are no cracks in the crank arms before riding the bicycle. If there are any cracks, the crank arm may break and you may fall off the bicycle.
- If the inner cover is not installed correctly, the axle may rust and become damaged, and the bicycle may fall over and serious injury may occur as a result.
- Obtain and read the service instructions carefully prior to installing the parts. Loose, worn or damaged parts may cause the bicycle to fall over and serious injury may occur as a result. We strongly recommend only using genuine Shimano replacement parts.
- Obtain and read the service instructions carefully prior to installing the parts. If adjustments are not carried out correctly, the chain may come off and this may cause you to fall off the bicycle which could result in serious injury.
- Read these Technical Service Instructions carefully, and keep them in a safe place for later reference.

### Note

- Do not use the bashguard for the FC-M810 single chainwheel with the FC-M665 chainwheel, as it will not function correctly. It may cause problems with gear shifting operation.
- Turn the top adjustment screw to adjust so that the chain does not sit on top of the bash guard.
- Make sure that the chainring combination matches the front chainwheel tooth configuration in the Product specifications table. If other combinations are used, the distance between the chainrings will be incorrect and the chain might slip off and get caught in between them.
- When the chain is in the position shown in the illustration, the chain may contact the front chainrings or front derailleur and generate noise. If the noise is a problem, shift the chain onto the next-larger rear sprocket or the one after.
- If the bottom bracket shell is not parallel, gear shifting performance will drop.
- Before riding the bicycle, check that there is no play or looseness in the connection. Also, be sure to retighten the crank arms and pedals at periodic intervals.
- If a squeaking noise is heard coming from the bottom bracket axle and the left crank arm connector, apply grease to the connector and then tighten it to the specified torque.
- If you feel any looseness in the bearings, the bottom bracket should be replaced.
- In addition, if pedaling performance does not feel normal, check this once more.
- Do not wash the bottom bracket with high-pressure jets of water.
- Apply grease to the left and right adapters before installing them.
- To ensure the best performance, be sure to use only the specified type of chain. The wide type of chain cannot be used.
- If the chain keeps coming off the chainrings during use, replace the chainrings and the chain.
- You should periodically wash the chainrings in a neutral detergent and then lubricate them again. In addition, cleaning the chain with neutral detergent and lubricating it can be an effective way of extending the useful life of the chainrings and the chain.
- Parts are not guaranteed against natural wear or deterioration resulting from normal use.
- For maximum performance we highly recommend Shimano lubricants and maintenance products.
- For any questions regarding methods of installation, adjustment, maintenance or operation, please contact a professional bicycle dealer.

### Chain Device

When installing a BB mount-type chain device to a bicycle, refer to the table below to determine the number of spacers for the right side. If the thickness of the spacers used is not as given in the table, the front chainwheel may become loose and fall off, or problems with gear shifting may occur. When installing a BB mount-type chain device or a ISCG-type chain device to a bicycle, you need to be careful to avoid interference.



The example in the illustration shows a BB mount-type chain device.

### <Chain Device Thickness (BB mount)>

For chain device thickness of 2.5 mm

Model number	Bottom bracket shell width		
	68 mm	73 mm	83 mm
FC-M810-1 FC-M665 FC-M810-2	2.5 mm x 1	Not needed	
FC-M815-1 FC-M815-2			2.5 mm x 1

For chain device thickness of 5.0 mm

Model number	Bottom bracket shell width		
	68 mm	73 mm	83 mm
FC-M810-1 FC-M665 FC-M810-2	Not needed	Not available	
FC-M815-1 FC-M815-2			Not needed

### Bashguard

Shimano bashguards are designed together with the crank arms to provide strength, rigidity and good shifting performance. Because of this, if you do not install a bashguard, problems may occur such as the chain may fall off, the chainrings may become bent or the spider may break. Therefore it is recommended that you always install a bashguard. Similarly, if you use a bashguard which is not manufactured by Shimano, problems may occur such as poor shifting performance, or the chain may fall off, the chainrings may become bent or the spider may break. Any such problems will not be covered by your product warranty if you do not install a bashguard or if you install a bashguard which is not manufactured by Shimano.

### When using in combination with the FD-M665-E (2.5 mm chain device)

Model number	Bottom bracket shell width		
	68 mm	73 mm	83 mm
FC-M665 FC-M810-2	Not needed	Not available	
FC-M815-2			Not needed

### <Installation method>

Install the chain device and the front derailleur as shown in the illustration.

- If using in combination with an BB mount-type front derailleur, make sure that the chain device does not obstruct the BB mount-type bracket.

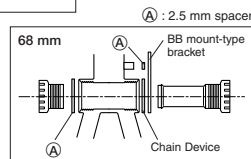

## Technical Service Instructions

SI-0062A-003

# FC-M665

## Specifications

Model number	FC-M665
Applicable front derailleur	Double (FD-M665 / M667 / M665-E)
Chainwheel tooth combination	36-22T
Bolt circle diameter	104 mm / 64 mm
Crank arm length	170 mm, 175 mm
Chain line	46.8 mm
Bottom bracket shell width	68, 73 mm
Thread dimensions	BC1.37 (68, 73mm)

Be sure to read the service instructions for the Front Drive System in conjunction with these service instructions.

## Installation of the Front Chainwheel

### Follow the procedure in the figure.

- 1, 2 Use the special tool TL-FC32 / 36 to install the right adapter (counterclockwise thread) and the left adapter (clockwise thread).  
Tightening torque: 35 - 50 N·m {305 - 435 in. lbs.}
- 3 Insert the right crank unit.
- 4 Set section A of the left crank into the axle of the right crank unit where the groove is wide.
- 5 Use the TL-FC16/18 to tighten the cap.  
Tightening torque: 0.7 - 1.5 N·m {6 - 13 in. lbs.}
- 6 Push in the stopper plate and check that the plate pin is securely in place, and then tighten the bolt of the left crank arm. (5 mm Allen key)

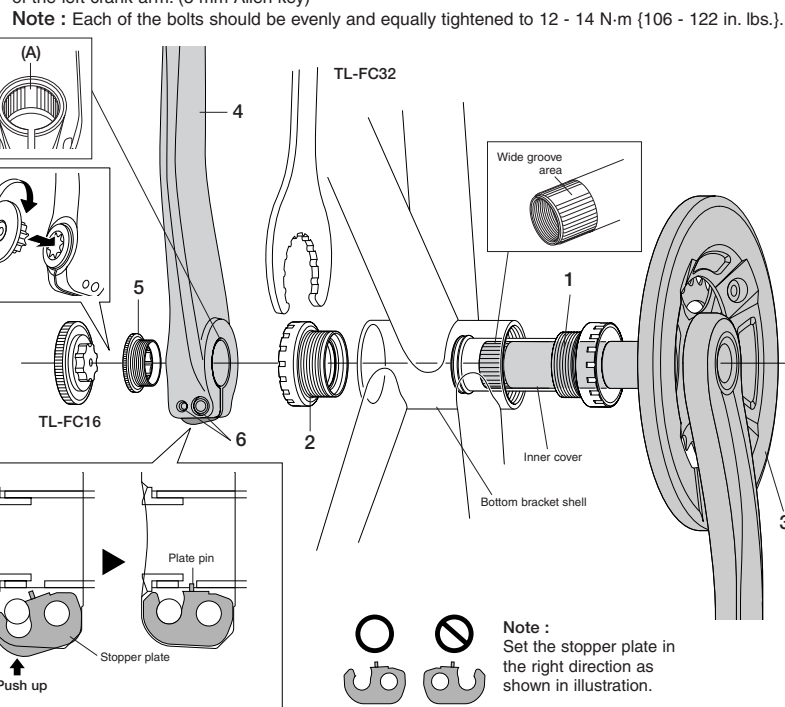

### Spacer installation method

- 1 Check whether the width of the bottom bracket shell is 68 mm or 73 mm.
- 2 Next, install the adapter while referring to the illustrations below.

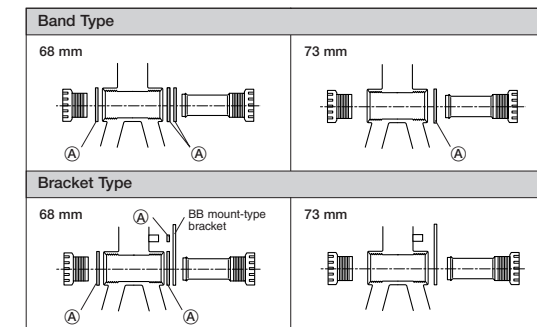
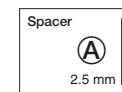
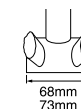

### For bracket type

Install as shown in the illustration.

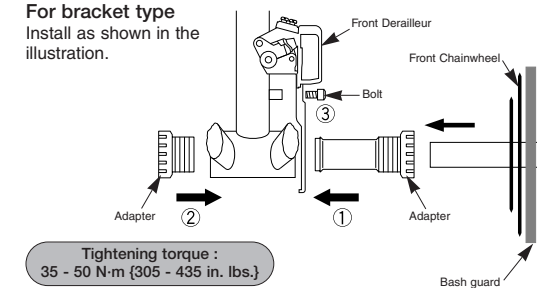

## Installation of the front derailleur

Adjust and then install the front derailleur as shown in the illustration. Do not remove the Pro-Set alignment block at this time.

### <Front derailleur height and parallelism adjustment>

With the flat part of the chain guide outer plate on the inside of the bash guard as shown in the illustration, adjust the height of the front derailleur so that the outer edge of the bash guard is within the specified range on the Pro-Set gauge. Also adjust so that the flat part of the outer plate is parallel to the inner surface of the bash guard. Use a 5 mm Allen key to tighten.

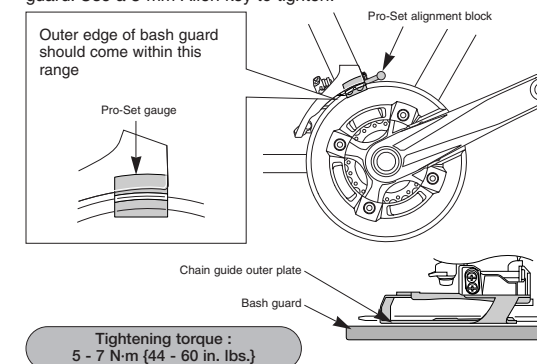

When installing the components to carbon frame/handle bar surfaces, verify with the manufacturer of the carbon frame/parts for their recommendation on tightening torque in order to prevent over tightening that can cause damage to the carbon material and/or under tightening that can cause lack of fixing strength for the components.

## SHIMANO

SHIMANO AMERICAN CORPORATION  
One Holland, Irvine, California 92618, U.S.A. Phone: +1-949-951-5003

SHIMANO EUROPE B.V.  
Industrieweg 24, 8071 CT Nunspeet, The Netherlands Phone: +31-341-272222

SHIMANO INC.  
3-77 Oimatsu-cho, Sakai-ku, Sakai-shi, Osaka 590-8577, Japan

\* Service Instructions in further languages are available at:  
<http://techdocs.shimano.com>

Please note: specifications are subject to change for improvement without notice. (English)  
© May 2009 by Shimano Inc. XBC SZK Printed in Japan.